

1STC460001B0201

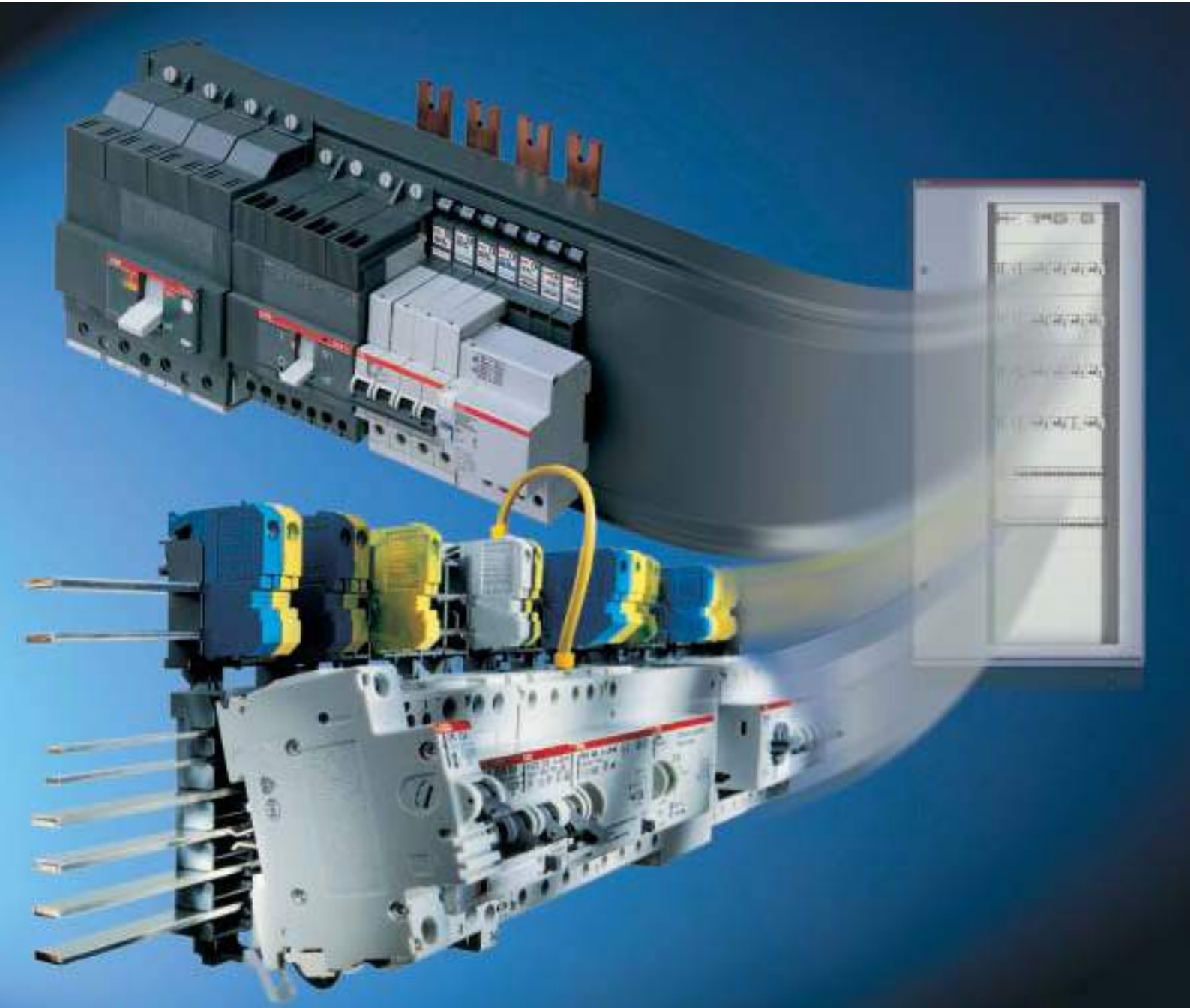



## Index

General .....	3
Applications.....	4
<b>Unifix H</b>	
Main characteristics .....	6
Components.....	8
System applications .....	10
<b><i>smisline</i></b>	
<b>smisline-S</b>	
Main characteristics .....	12
Components.....	14
System applications .....	18
Bus-bar System .....	19
<b>Unifix L</b>	
Main characteristics .....	22
Components.....	24
System applications .....	26

## Plug-in and distribution systems

### General

## With the Unifix and smissline-S systems, ABB helps you to save your time.

**Unifix** makes bench pre-cabing possible, with installation in the switchboard only carried out at a later time, without any limit to the types or combinations of apparatus you may need to install... and this becomes even easier, thanks to the rigid coupled connectors, standardized for the different types of apparatus.

**The smissline-S** system offers unsurpassed possibilities in the

field of electrical protection gear – reliable, flexible and rapid installation possibilities, which have been used for many years and whose functional efficiency remains unsurpassed.

Both those cabling systems notably reduce cabling times, with a real advantage for every kind of customer ... with ABB, life becomes easier.

### Unifix H

Unifix H allows modular and moulded-case circuit-breakers up to 250A to be mounted on an apparatus frame, which can be connected directly to the rear busbar system. This means many fewer conductors circulating inside the switchboard with considerable advantages in terms of space taken up, connections needed to be checked, and cabling times, with consequent cost savings.

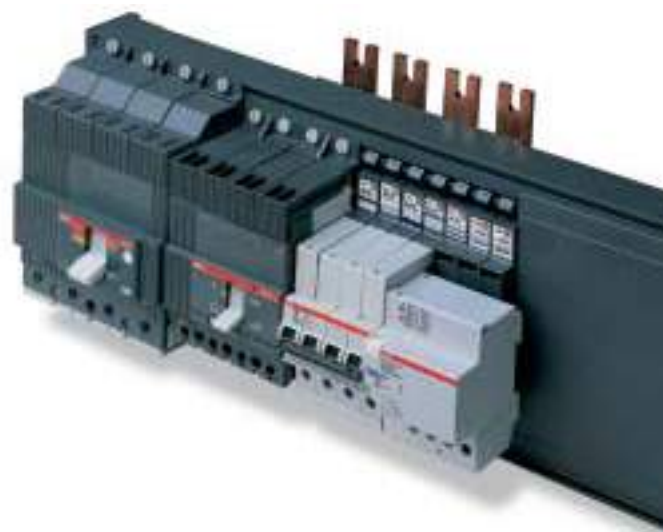

### Unifix L

Unifix L means traditional wire cabling on the supply side of the circuit-breakers can be eliminated. It is thanks to the characteristics of its connections that cabling can be done rapidly and without any possibility of error, obtaining a more essential switchboard without conductors and cabling ducts around.

Flexibility is its strong point: several independent circuits can be realised on the same DIN rail, and circuit-breakers of different types, with different polarity and characteristics can be mounted.

### *smissline*

Five different types of protective device are available to be plugged into the socket system with integral busbars. This permits the Smissline system to provide simple, modular and versatile switchgear assemblies up to a rated current of 200A. The units can be plugged in quickly and easily to ensure cost-saving planning and assembly.



# Plug-in and distribution systems

## General

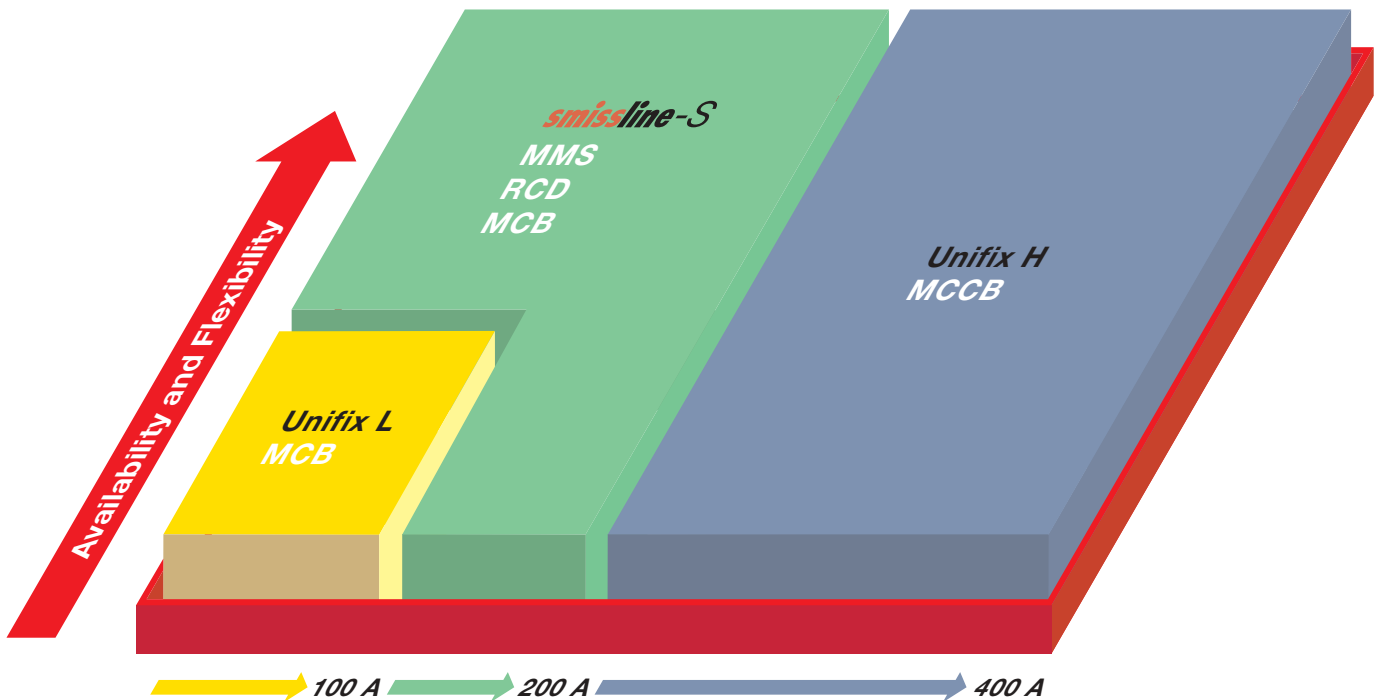

### Technical characteristics



Technical characteristics	Unifix H	smisline	Unifix L
Rated service voltage ( $U_e$ )	690V a c	400/690 Vac	415V a c
Rated insulation voltage ( $U_i$ )	1000V a c	690V a c	500V a c
Rated impulse withstand voltage ( $U_{imp}$ )	8kV	8kV	6kV
Rated frequency	50/60Hz	50/60Hz	50/60Hz
Rated current ( $I_n$ )	central power supply lateral power supply		
	400A 320A	200A 100A	100A 80A
Rated short-time withstand current ( $I_{cw}$ )	25kA	10 kA/300 ms	
Maximum peak withstand current ( $I_{pk}$ )	52,5kA@400V	17kA	
Maximum installable circuit-breaker size	250A	250A	100A
Conditioned short-circuit current ( $I_{cc}$ )	Tmax T1 <sup>(1)</sup> Tmax T2 N, S <sup>(1)</sup>		
	36kA@400V 50kA@400V		
With circuit-breaker	Tmax T3 Isomax S1 Isomax S2 System pro-M smisline-s components	32,5kA@415V  up-to 25kA up-to 10kA	  up-to 25kA
Distribution system	3Ph+N	3Ph - 3Ph+N - 3Ph+N+PE	2Ph - 3Ph+N
Degree of protection IP20	yes <sup>(2)</sup>	yes	yes
Characteristics of the insulating material	Self-extinguishing thermoplastic V1 (UL94)	Self-extinguishing thermoplastic V1 (UL94)	Self-extinguishing thermoplastic V1 (UL94)
Characteristics of the conductor material	Copper	Copper zinc plated	Copper
Lengths (N° modules/mm)	24/600 36/800	from 12/216 to 110/1979	12/400 24/600 36/800
Installation	vertical/horizontal	vertical/horizontal	horizontal
Fixing supports	brackets	DIN rail	DIN rail

<sup>(1)</sup> Select circuit-breakers in version with front terminals for copper cables

<sup>(2)</sup> With accessory



---

## Plug-in and distribution systems

### Applications

---

#### Fields of application: advantages and benefits



##### Industrial buildings

- High degree of system availability
- Combination module as complete motor starter unit
- Clear allocation of devices and terminals



##### Telecommunications

- Interchangeability of devices
- Overvoltage-protected systems
- Specifically targeted device and circuit protection



##### Shopping centres

- Quick change configuration
- Clearly arranged RC protection structure
- Mixed-pole devices can be placed in any position



##### Airports

- High degree of system availability
- Short realization time
- Cost-effective adaptation

---

# Plug-in and distribution systems

## Applications

---



### Hospitals, clinics

- High degree of safety and reliability for maintenance/service
- Residual current signalling device for monitoring
- Permanent current availability



### Banks, insurance companies

- Various power supply options
- Clearly arranged RC protection structure
- System modifications can be carried out quickly



### Office buildings

- Flexibility in lighting and air conditioning systems
- Expansions options
- Flexibility for system modifications



### Traffic

- Short time delayed residual current circuit-breakers for long cables
- Overvoltage-protection systems
- Fast replacement of combination module as complete motor starter unit

# Unifix H

## Main characteristics

### Frames

The frames consist of a system of busbars (25x5mm section ED2507, ED2515 and 20x5mm section for ED2506, ED2514) with 400A capacity and 50kA short-circuit current. The various basic modules dedicated to connection of the apparatus are fixed to this structure which, together with the power supply module, provide the following circuit situations:

- direct supply of the bases by means of the power supply module (ED2522)
- power supply with main row circuit-breaker by means of a dedicated base module.

The frames, which can be installed in switchboards 600 and 800mm wide respectively, are available in the two 24 and 36 module

widths. They are fixed to the structure by means of the special kits AD1060 for the H=200mm module or AD1061 for the H=300mm module.

### Power supply module

The 400A power supply module (L1-L2-L3-N) is fixed onto the rear side of the frames, therefore without losing any space dedicated to assembly of the equipment on the front. The power supply module allows direct connection (by means of the hammer screw AD1064) to the 400/800A busbar system with shaped section, installed on the back of the cabinet.

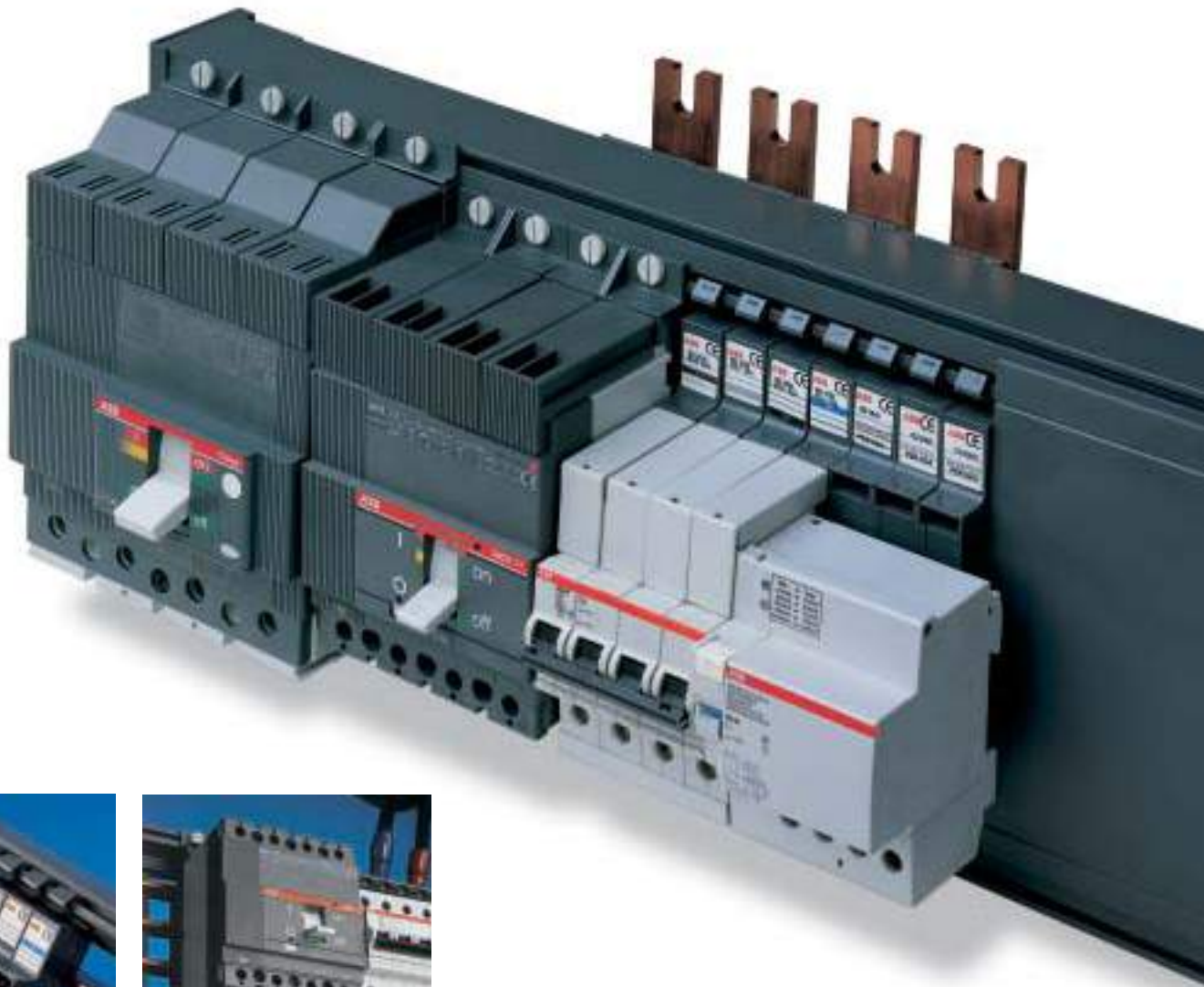

The power supply module has labels which clearly indicate the connection.



Unifix H allows supply from the top or from above.



# Unifix H

## Main characteristics

### Base modules for apparatus

The modules have the function of mechanically supporting the apparatus and electrically connecting it to the distribution busbars contained in the frames.

The modules for the pro-M System modular apparatus are all of the single-pole dimensions (i.e. they only take up one DIN module). To connect single-pole, two-pole, three-pole or four-pole circuit-breakers, one, two, three or four single-pole bases are used respectively, placed side by side.

Each module connects a phase and is identified by the corresponding letter (L1, L2, L3, N) or, in the case of 1P+N circuit-breakers (1 module), by: L1+N, L2+N, L3+N. The modules for connecting the Tmax T1, T2, T3 and Isomax S1, S2 moulded-case circuit-breakers are available in the single-pole versions, whose association allows three-pole, four-pole versions or as a false pole to be obtained for installation of the residual current release side by side. The modules are available in the versions with capacities up to 40 and 63A, with power supply system from the top or bottom, and in the versions with cable (L1+N or L1+L2= for connecting auxiliary elements. In the case of Tmax circuit-breakers fitted with solenoid operator, provide the relative false module.

### Completion accessories

The system is completed with the "false pole" modules, whose function is to cover modules not occupied by apparatus or side by side with apparatus cabled in the traditional way. There is also a protective cover, which ensures IP20 degree of protection on the

horizontal distribution busbars in the stretches where assembly of apparatus is not foreseen.

### Technical characteristics

Rated service voltage (Ue)	690V AC	
Rated insulation voltage (Ui)	1000V AC	
Rated impulse withstand voltage (Uimp)	8kV	
Rated frequency	50/60Hz	
Rated current (I <sub>n</sub> )	central power supply	400A
	lateral power supply	320A
Maximum installable circuit-breaker size	250A	
Conditioned short-circuit current (I <sub>cc</sub> )	Tmax T1 <sup>(1)</sup>	36kA@400V
	Tmax T2 N, S <sup>(1)</sup>	50kA@400V
With circuit-breaker	Tmax T3	50kA@400V
	Isomax S1	25kA@400V
	Isomax S2	50kA@400V
	System pro - M	up to 25kA
Dissipated power	The dissipated power is negligible (less than 3%) with regard to the power dissipated by the circuit-breakers	
Degree of protection IP20	yes <sup>(2)</sup>	
Characteristics of the insulating material	Self-extinguishing thermoplastic V1 (UL94)	
Characteristics of the conductor material	Copper (Electrolytic copper?)	

<sup>(1)</sup> Select circuit-breakers in version with front terminals for copper cables

<sup>(2)</sup> With accessory





# Unifix H

## System components

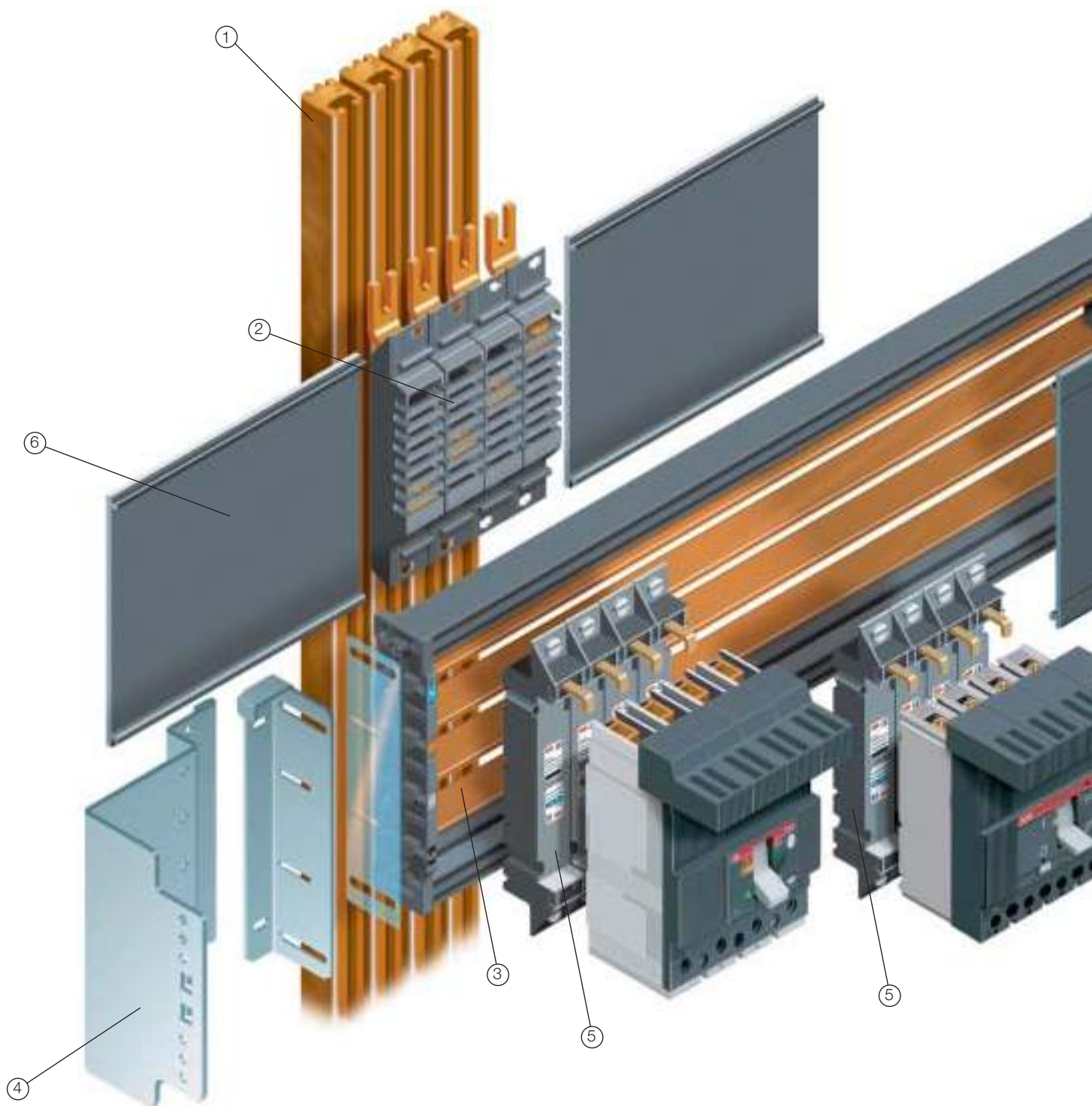

- ① Busbars with shaped section
- ② Power supply module
- ③ Apparatus supporting frame

- ④ Fixing brackets
- ⑤ Apparatus modules
- ⑥ IP20 protective cover

# Unifix H

## System components

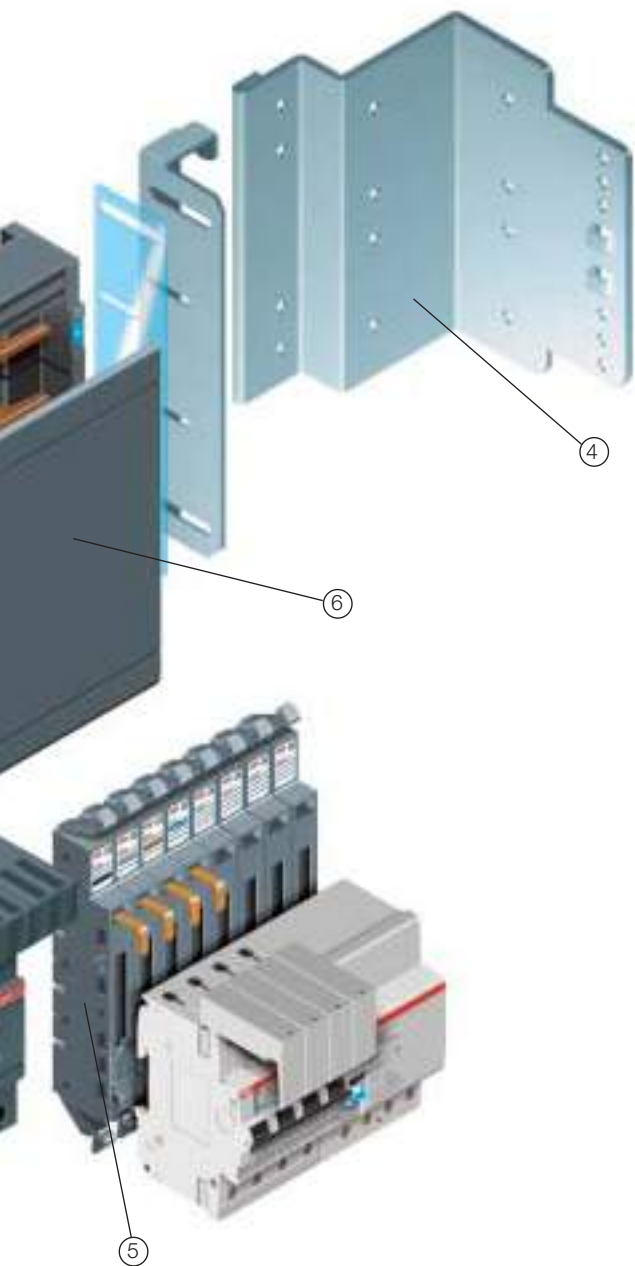

## Unifix H

### Busbars with shaped section

When placed on the back of the switchboard, the busbars with shaped section allow direct connection to the apparatus supporting frame by means of the power supply module and the relative hammer screws. There are two possible capacities:  $I_n=400$  and  $I_n=800A$  (sized at the maximum IP65 degree of protection). The system is completed with the relative busbar supports and crosspieces for fixing to the switchboard structure.

### Power supply module

This is made up of individual single-pole modules (L1-L2-L3-N) and can be connected:

- to the busbar system, by means of hammer screws, on one side;
- to the apparatus supporting frame, by means of contact pliers, on the other.

Its rated current-carrying capacity is 400A.

### Apparatus supporting frame

this is the supporting structure of the system. It is made up of a four-pole busbar system 25x5mm equal to a rated current of 400A if supplied centrally and 320A if supplied laterally. It is available in the two widths of 24 and 36 DIN modules respectively for switchboards 600 and 800mm wide.

### Fixing brackets

These allow a single row of Unifix H to be fixed in the correct position inside the switchboard structure, without any type of mechanical working. The special shape of this support allows the cable ducts to be passed and fixed.

### Apparatus modules

These are the interface between the apparatus supporting frame and the circuit-breakers. There are different types of modules, according to the type of circuit-breaker to be installed (Tmax and Isomax moulded-case circuit-breakers, or modular circuit-breakers) and to the possible power supply solutions (from below and from above). They are made up of individual single-pole poles, complete with terminal covers for the connections.

### IP20 protective cover

When the apparatus supporting frame is not completely covered by apparatus modules, the cover protects the live parts, guaranteeing IP20 degree of protection of the whole system.

# Unifix H

## System applications

The Unifix H system was designed to allow the apparatus and switchboard a high degree of standardisation, which considered the switchboard and circuit-breaker in an integrated way, with consequent reduction in cabling times and in the

different habits or installation situations.

Several circuit possibilities are offered by the system. There is the possibility of supplying the busbars through the power supply module, thereby obtaining power supply to the circuit-



space taken up - which have a positive effect on costs. The different assembly combinations of the power supply module and the apparatus supporting modules give the Unifix H system great flexibility from the electrical and circuit viewpoints. The possibility of reversing the power supply module does, in fact, allow the busbars to be supplied by cables coming either from above or below, according to

breakers through the apparatus modules. The latter, in the same way as the busbars, can be supplied either from above or from below, simply by turning the apparatus supporting modules round. By means of conductors, the circuit-breaker terminals can also be supplied directly, obtaining the circuit situation brought about by a main row circuit-breaker.

**Busbar power supply from the top by means of 4P power supply module placed laterally**

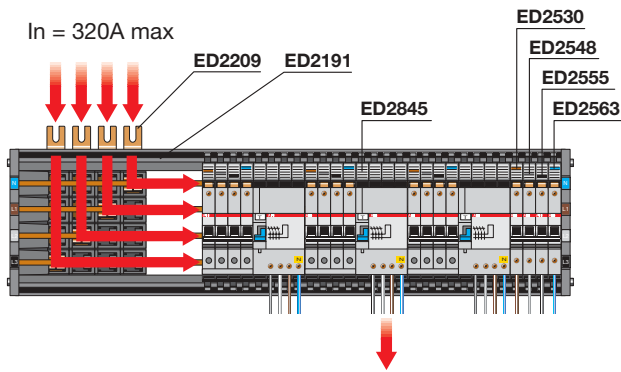

**Busbar power supply from the bottom by means of main row circuit-breaker**

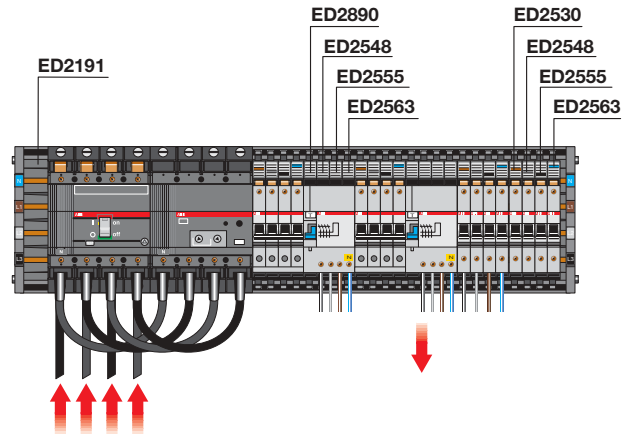

**Busbar power supply from the bottom by means of 4P power supply module placed laterally**

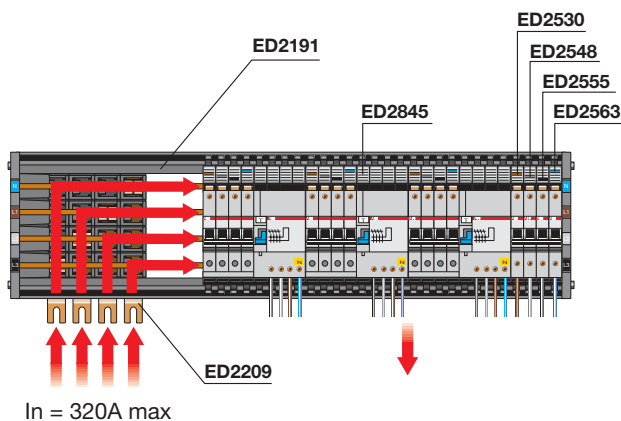

**Busbar power supply from the top by means of 4P power supply module placed centrally**

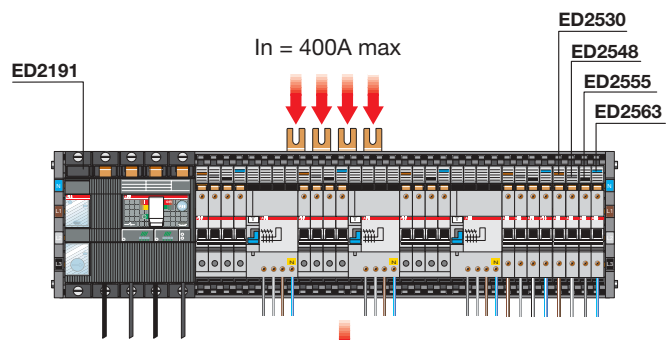

# Unifix H

## System applications

Busbar power supply from the top by means of main row circuit-breaker

Covers for IP 20 degree of protection

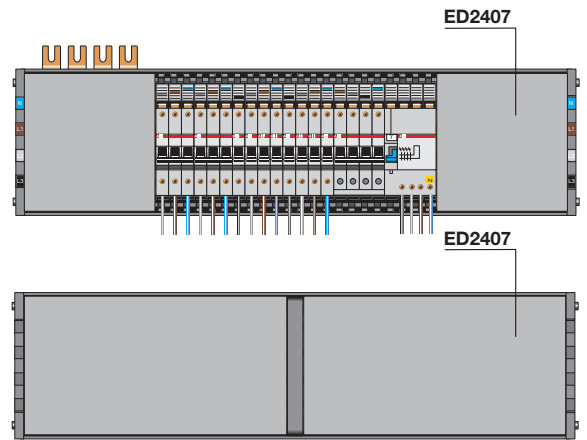
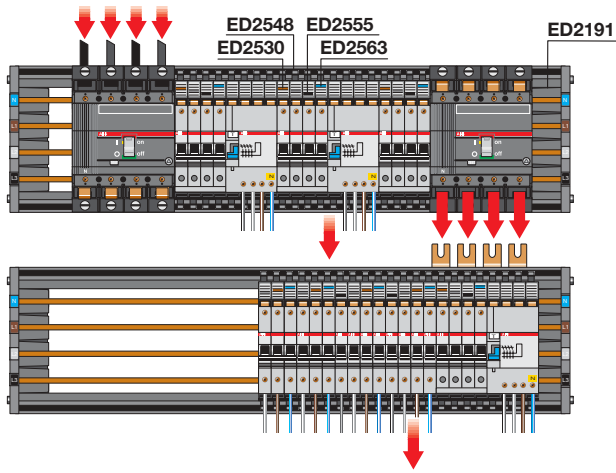



---

# **smisline-S**

## Main characteristics

---

With **smisline-S** we give you the means of planning whatever you want!

### The idea

5 state-of-the-art protection devices of identical design are simply plugged onto a busbar system. No need for an elaborate power supply and connection work. In addition to the saving in time and costs, a further advantage of the system is that it permits fast and easy replacement of the devices. If corresponding spare capacity is planned, subsequent expansion is achieved by simply plugging the additional devices onto the busbar.

### Combination module

Using a combination module, you can configure a variety of devices. For instance a motor protection circuit-breaker together with a contactor can be arranged to form one single unit.

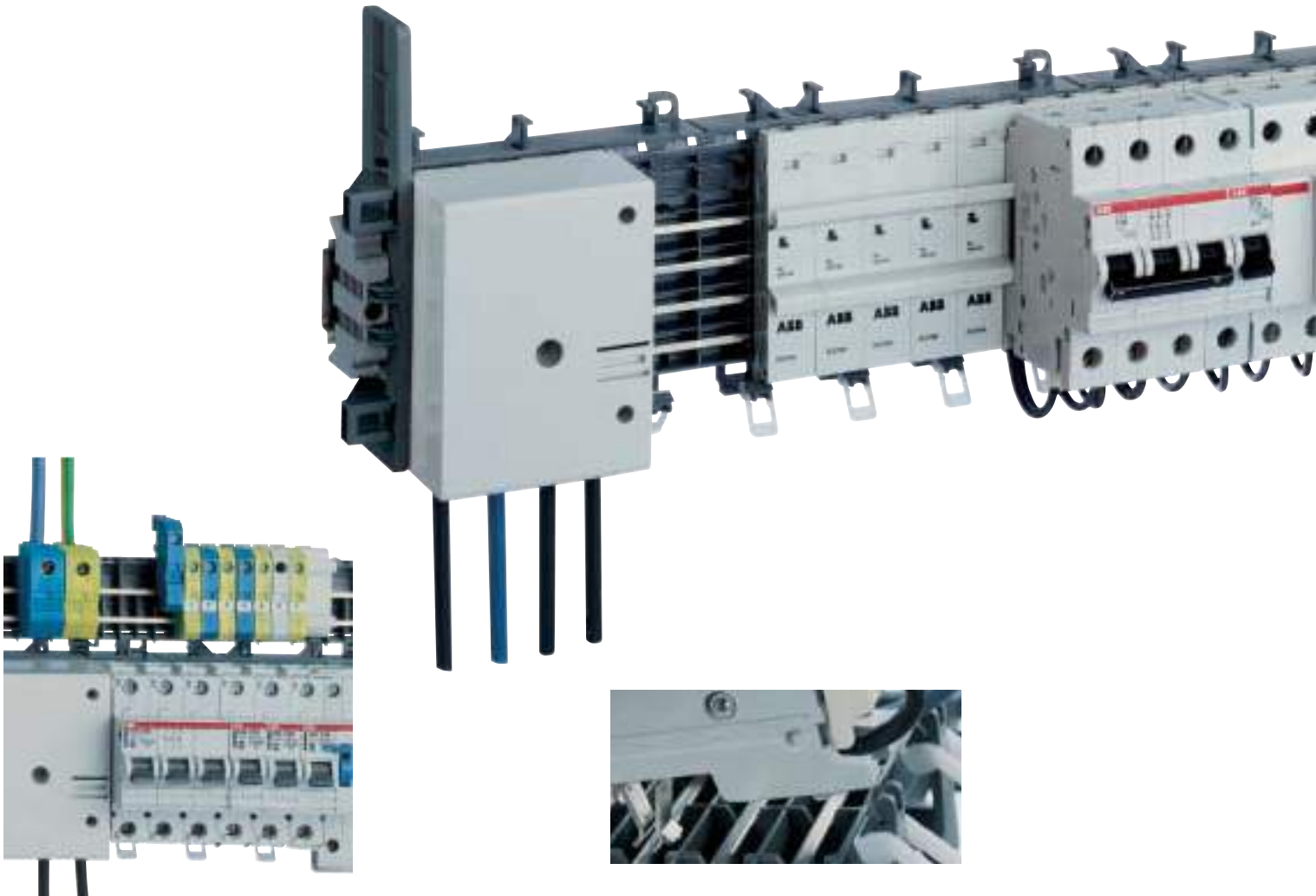

### Compact design

Smissline-S saves space while providing effective shock-hazard protection. With the outer N-terminal acting as the isolator, a single-pole outgoing circuit L/N/PE up to 32 A requires an overall width of just 18 mm.

### Plug-in devices

The smissline devices of identical design can be simply plugged onto the busbar system

---

# **smisline-S**

## Main characteristics

---

### Various power supply options

You can supply power, for example, via a residual current circuit-breaker. The busbars can be interrupted by means of isolators so that residual current devices can be configured in groups.

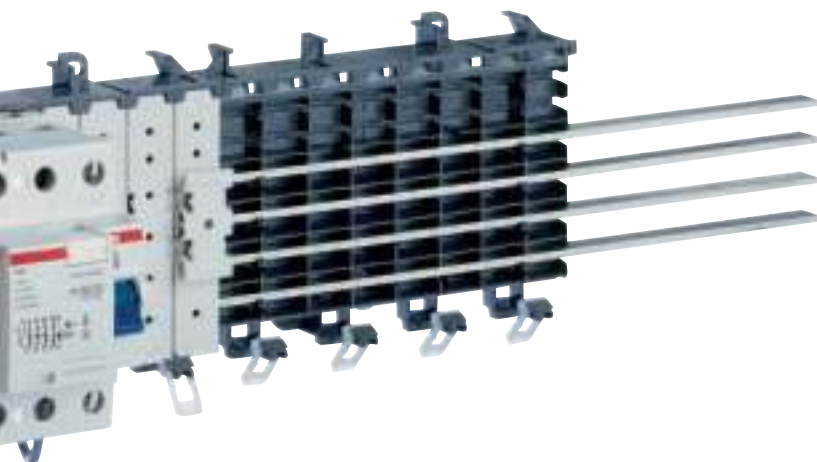

### The trick with the click

Devices are simply plugged onto the system without the need for any auxiliary adapters. Correction and expansion work couldn't be easier.



### Freedom in concept and arrangement

Smisline-S gives you freedom of choice: Mixed-pole arrangements are accommodated with ease.



### Signalling

Signal and auxiliary contacts are available for all devices. They can be powered directly by the use of two auxiliary busbars within the socket base.

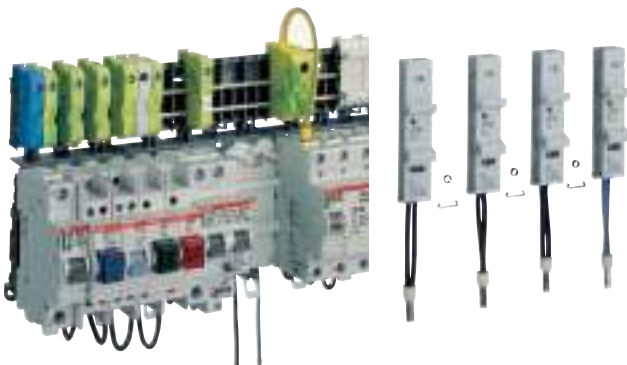

### Vertical equipment layout

With a vertical layout you can save even more space as this arrangement renders outgoing terminals unnecessary. The outgoing cables are connected directly to the devices.



### Other-make devices

Thanks to the DIN rail adapter, a variety of devices can be integrated into the system.

### Shock-hazard protection

All busbars can be covered with shock-hazard protection covers. This makes the entire system touch-proof.

# **smisline-S**

## System components

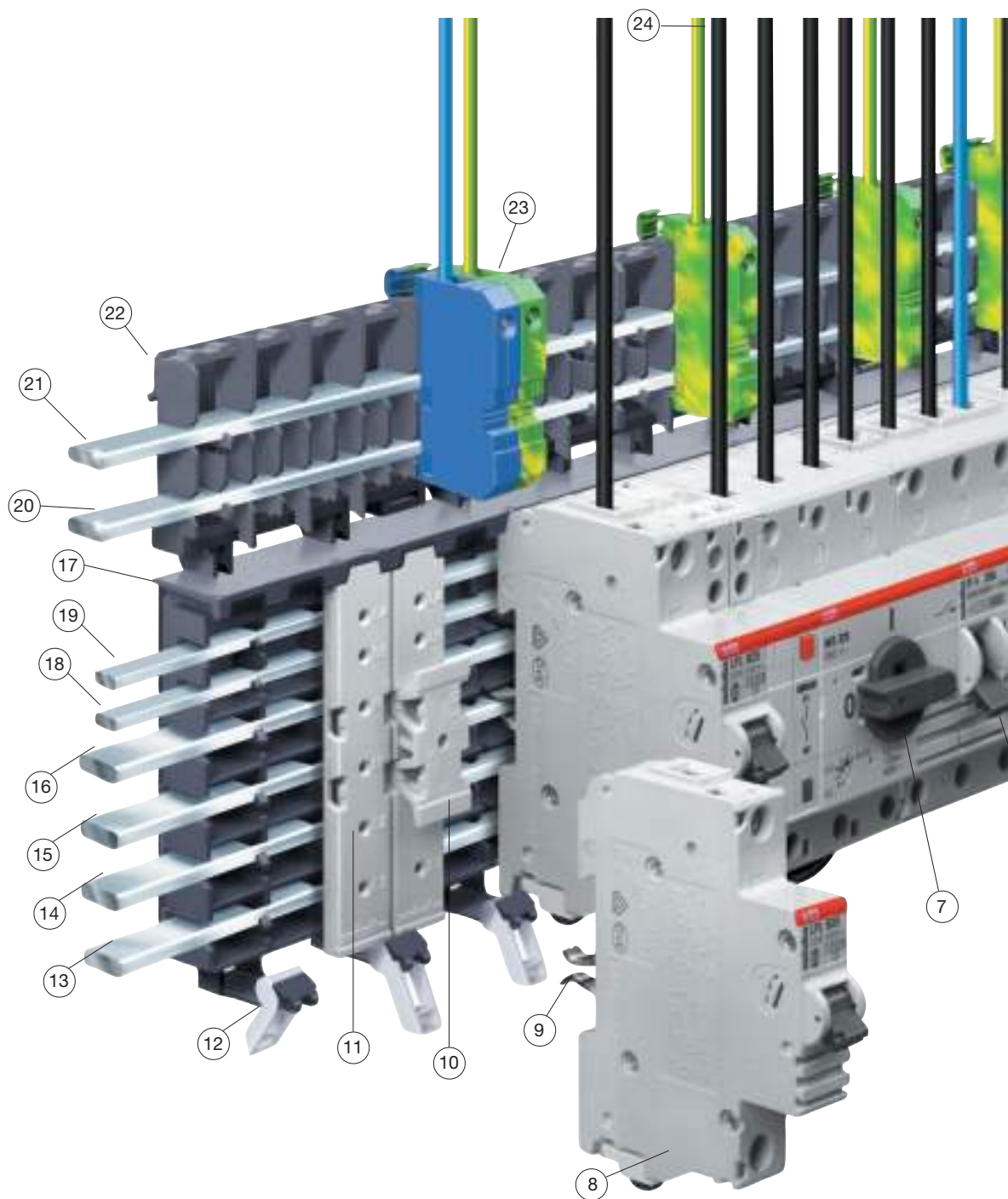

- |   |                     |
|---|---------------------|
| ① Incoming feeder terminal                              | ⑨ Plug contact      |
| ② Feeder block  | ⑩ Extension adapter |
| ③ Cover   | ⑪ Busbar cover      |
| ④ Feeder cables   | ⑫ Latch             |
| ⑤ Combined residual current – miniature circuit-breaker | ⑬ Busbar L3         |
| ⑥ Residual current circuit-breaker                      | ⑭ Busbar L2         |
| ⑦ Power motor circuit-breaker                           | ⑮ Busbar L1         |
| ⑧ Miniature circuit-breaker                             | ⑯ Busbar N          |

# smissline-S

## System components

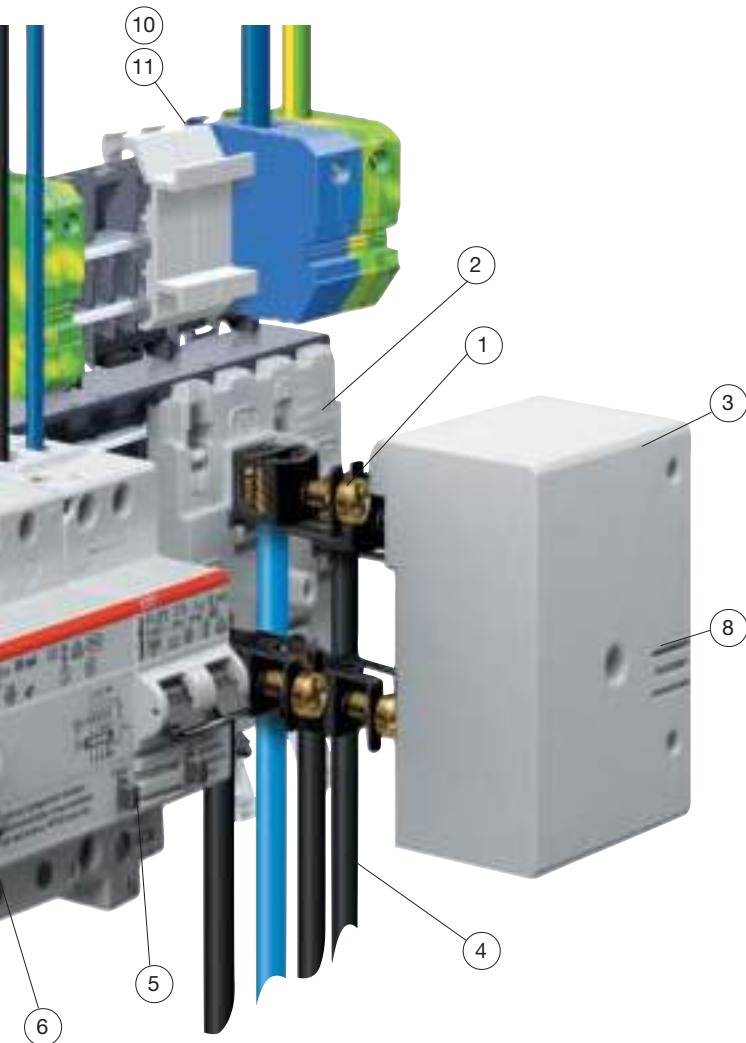

### Miniature circuit-breakers

Switching capacity 10 kA  
 1-, 2- and 3-pole versions from 0.5 to 63A rated current  
 4-pole circuit-breakers are available with a switched or fully protected neutral conductor  
 Characteristics B, C, D, G, K, UC-Z, UC-C  
 Snap-on auxiliary and signal contacts on left  
 Snap-on neutral disconnecter on right

### Residual current circuit-breakers

2-pole residual current circuit-breaker, 16 to 40A, 10, 30, 100mA  
 4-pole residual current circuit-breaker, 16 to 63A, 10, 30, 100, 300mA  
 Snap-on auxiliary and signal contact on left  
 Short time delay versions RCC (do not respond to discharge currents)  
 Selective residual current circuit-breakers type  $\text{S}$  (selective to RC or RCC)

### Combined residual current and miniature circuit-breakers

Versions from 10 to 20A with characteristic B and C, 10 or 30mA  
 Snap-on auxiliary and signal contacts on left are available  
 Short time delay versions RCC (do not respond to discharge currents)

### Motor protection circuit-breakers

Power motor protection circuit-breaker MS325 Un 690V, In 0.1 to 25A  
 Switching capacity 100/50kA  
 With phase failure protection, temperature compensation and slide-in undervoltage release  
 Snap-on auxiliary and signal contacts available

### Surge arrester

4-pole surge arrester of quality class C  
 Floating contact optionally integrated in device  
 Rated discharge current  $I_{sn}$  15kA

### Load switch

Smissline directly pluggable load switch In 63A or adapter for ABB load switch OT

### Additional socket with outer terminals

Additional socket with the facility for N or PE busbar (100A rated current)  
 Outer terminal up to max. 32A, overall width 9mm  
 Outer terminal up to max. 100A, overall width 18mm

### Socket

Socket with 6 or 8 modules (overall width 108 and 144mm respectively)  
 Interconnectable in any configuration  
 Busbars up to a maximum length of 1979mm (100A rated current) optionally L1, L2, L3, N  
 Auxiliary busbars LA, LB serve as feeders for auxiliary and signal contacts

### Accessories

Adapters for other DIN rail mounted devices  
 Combination module, for e.g. motor starter with contactor, the complete unit can be mounted on the system  
 Covers for sockets and additional sockets  
 Isolators for busbars etc.

### Feeder block, feeder element

Feeder block L1, L2, L3, N up to 50mm<sup>2</sup>, LA, LB, overall width 72mm  
 Feeder element optionally L1, L2, L3, N up to max. 95mm<sup>2</sup>, overall width 36mm per pole

- ①7 Socket
- ①8 Auxiliary busbar LA
- ①9 Auxiliary busbar LB
- ②0 N busbar, external
- ②1 PE busbar, external
- ②2 Additional socket
- ②3 Outgoing terminal
- ②4 Outgoing conductor



# **smisline-S**

## System components

### **Socket**

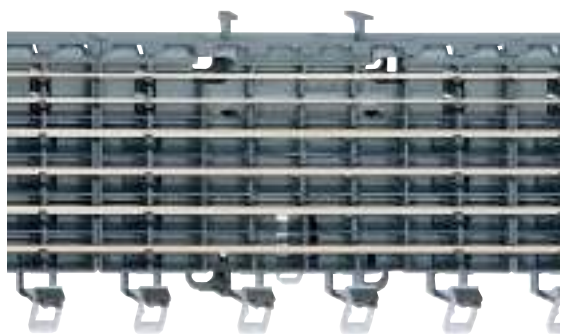

The socket with integrated busbars simultaneously incorporates mechanical and electrical connection to the mains supply for plug-on devices.

### **Power supply**



The busbars can be powered via the feeder block/feeder element or via switchgear (e.g. residual current circuit-breakers).

### **Socket**

- Rated voltage: 690V~
- Rated current: Busbars: 100A  
entre incoming feeder 200A  
Auxiliary busbars: 40A
- Socket lengths: 6 modules (108 mm)  
8 modules (144 mm)

### **Socket components**

Thanks to the modular system, the sockets are easy to butt-mount. A latch system ensures constant and even spacing. The sockets are either screw-mounted on a mounting plate or snapped onto a 35 mm DIN rail. The latch of the snap mounting makes installation particularly easy. It ensures the sockets can be moved laterally or removed totally before defining the final mounting position.

The space needed for

- the required devices
- the feeder block and
- spare ways

must be determined in order to establish the required socket length.



Socket with 8 modules

### **Additional socket**

The additional sockets can be simply plugged on to the main system and serve the purpose of accepting the external N and/or PE busbars. A top-hat rail can also be utilised. Of course, only one N-busbar or PE busbar can be mounted. Each main socket can be equipped with an additional socket (6-module or 8-module).

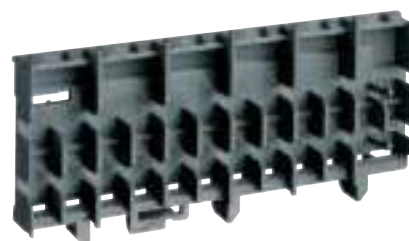

### Power Supply Variants Made Easy

#### Upstream overvoltage arrester maximum 100 A

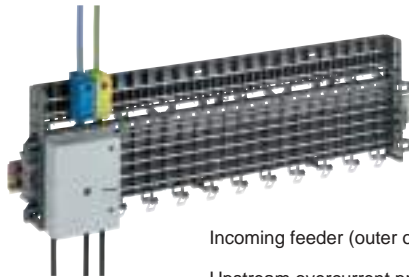

Incoming feeder (outer or centre)  
Upstream overcurrent protective device  
Rated tripping current  $\leq 100$  A

#### Upstream overcurrent arrester maximum 160 A

Outgoing circuit  $\sum I_N$ : Any  
 $\sum I_N \times f \leq 100A$        $\sum I_N \times f \leq 100A$

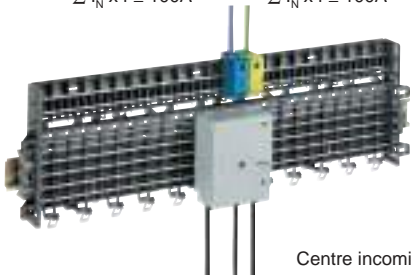

Centre incoming feeder  
Upstream overcurrent protective device  
> 100 A rated tripping current  $\leq 160$  A  
 $f$  = Simultaneity factor

#### Upstream overcurrent arrester greater than 200 A

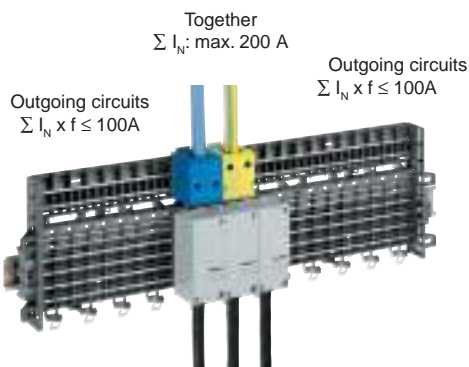

Incoming feeder, centre      Upstream overcurrent protective device 200 A

The sum of all the rated tripping currents of all connected overcurrent arresters multiplied by the simultaneity factor « $f$ » in the following table must not be greater than 200 A. In addition, this value must not exceed 100 A on either side of the feeder block. If power circuits are connected with a specified load current (e.g. motors), the simultaneity factor must not be used for these circuits. Power for 200 A rated current can only be supplied by means of feeder elements and not by the feeder block.

Number of power circuits	Simultaneity factor (f)
2 and 3	0,8
4 and 5	0,7
6 to 9	0,6
10 and more	0,5

Table from EN 60439-3

#### Power supply via residual current circuit-breaker

The feeder cable is connected via the residual current circuit-breaker to the opposite side of the stranded wires for the plug contacts.

In this configuration all busbars and therefore all subsequent devices are RC-protected. If several RC circuit-breaker groups are used, the dark grey busbar isolator should be used to separate the busbars. For this purpose, it is necessary to conform with the standards relating to overcurrent protection of RC circuit-breakers by means of downstream overcurrent arresters (see table).

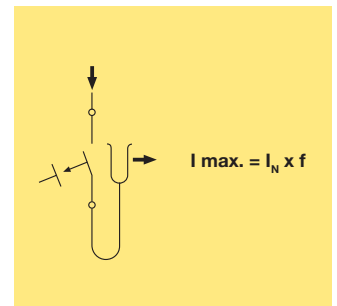

$f$  = Simultaneity factor

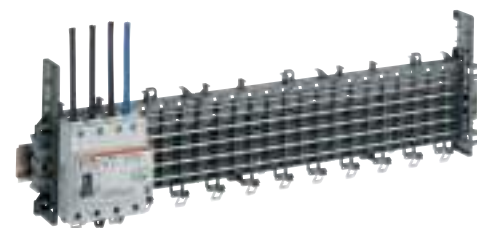

The busbars are RC protected

Number of power circuits	Simultaneity factor (f)
2 and 3	0,8
4 to 6	0,7
7 to 9	0,6
10 and more	0,5

Table from EN 60439-3

#### Power supply of auxiliary busbars L<sub>A</sub> and L<sub>B</sub>

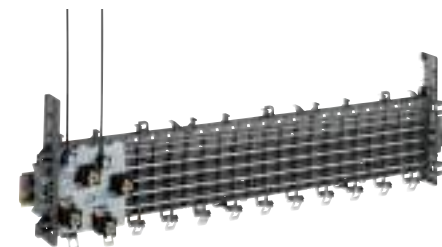

Power can be supplied to both auxiliary busbars via the feeder block. The two auxiliary terminals are plugged into the feeder block as required by simply inserting them in the openings provided. The two auxiliary busbars are rated up to maximum 40 A. In this way, auxiliary and signal contacts can be powered via the auxiliary busbars L<sub>A</sub> and L<sub>B</sub>.

#### Power supply of external N and PE busbars

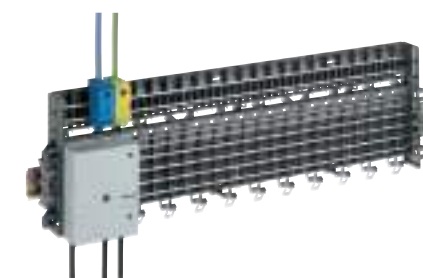

On external N and PE busbars, power is supplied to the neutral or PE conductor directly via suitable N and PE terminals. The N busbar must be isolated when using multiple RC groups.

---

# **smisline-S**

## System applications

---

### **The *smisline-S* solution:**

Large assemblies are arranged vertically, rendering incoming wiring of the devices unnecessary. The terminal compartment is arranged on the side. The N and PE terminals are allocated directly to the devices. Consequently, the outgoing cables are routed directly to the devices. Additions can be implemented easily while saving time. New devices can be simply plugged onto the socket when expanding the systems.

### **Customer benefits of vertical construction**

Due to the elimination of incoming terminals in the vertical configuration there are fewer terminal points.

This makes for a clearer overview and changes are much easier to implement. The high system availability and simple change options ultimately mean cost savings.

### **Outgoing wiring of protection devices**

The external N and PE terminals are allocated directly to the corresponding device. Modifications or additions can be easily accomplished at any time in the project.

Assembly and wiring times are reduced due to the plug-in feature of the devices.

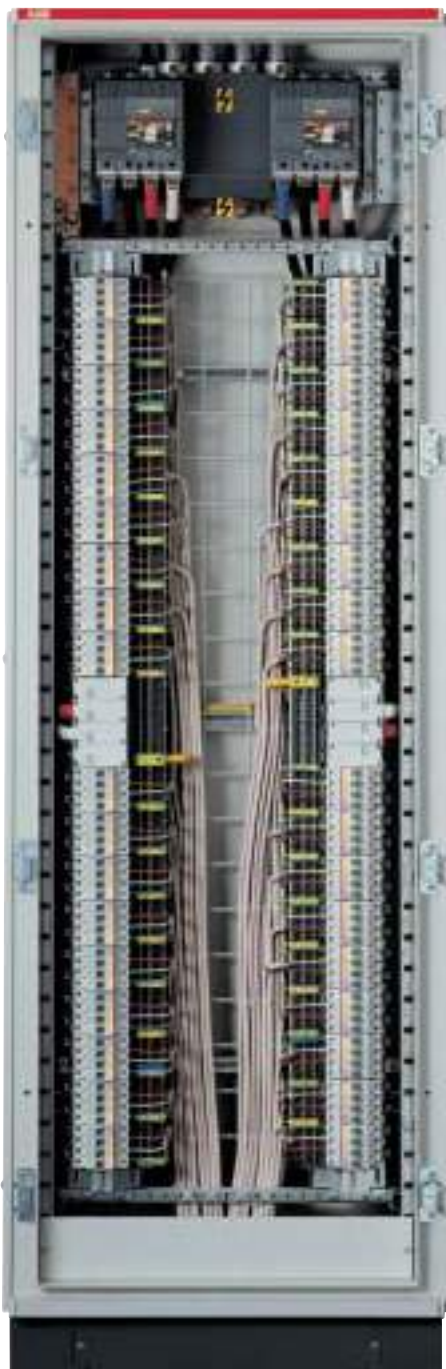

# **smisline-S**

## *Bus-bar System*

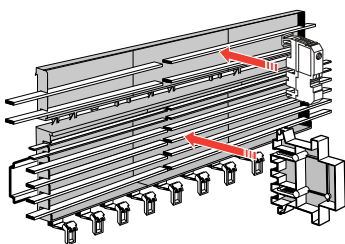
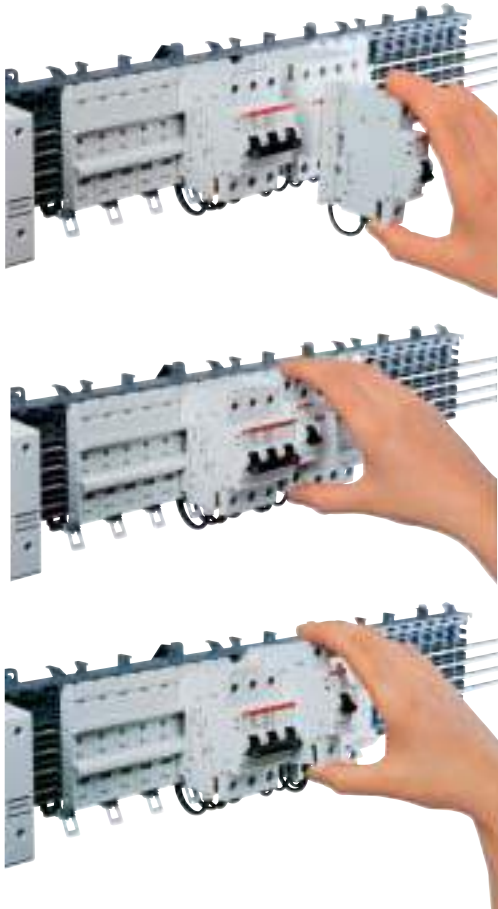

### **Flexibility**

The bus-bars are provided individually. An additional socket can be added on, allowing a N- and/ or the PE bus bar to be integrated into the system.

The outer N and PE terminals can just be clipped on. Therefore the outgoing cable can be directly allocated to these devices.

The adapter can easily and securely be plugged onto the socket base. Ease of handling is assured due to a mechanical guide.

### **Versatile**

For the smisline-S Bus bar System there are extensive accessories available: incoming terminal blocks up to maximum 200A, a new modular incoming terminal up to maximum 200A, exterior terminals, coverings, adapters in various designs etc.

### **Modular**

Due to bus-bar insulators the Bus bar System can be divided into different segments.

For example this enables them to be split in to RCD protected groups. Thus the bus bar system can also be fed via a protective device.



**smisline**  
Bus-bar System

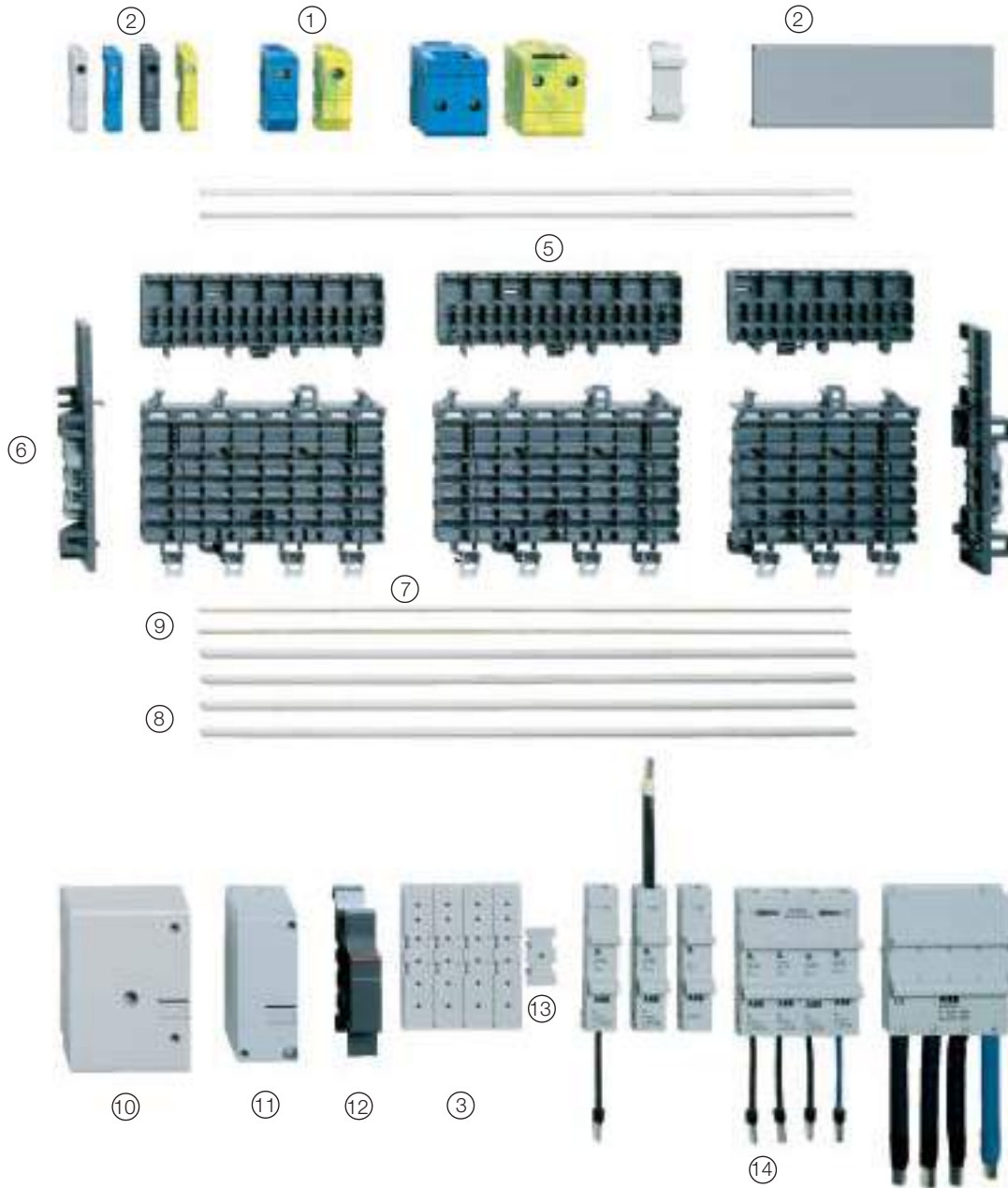

- ① N and PE conductor terminals 32A, 100A and 200A
- ② Busbar cover 9, 18 and 144 mm for additional socket
- ③ Busbar cover for the socket
- ④ Busbar for N and PE
- ⑤ 6-module and 8-module Additional socket base
- ⑥ Socket end-piece
- ⑦ 6-module and 8-module socket
- ⑧ Busbar for L1, L2, L3, N and PE
- ⑨ Busbar for auxiliary contacts  
(only when use smisline components)

- ⑩ Incoming terminal block, Standard 100A left or right on the system 160A on Center Power supply of the system maximum 50 mm<sup>2</sup>
- ⑪ Incoming terminal oversize, Standard 200A on Center Power supply of the system maximum 95 mm<sup>2</sup>
- ⑫ Busbar isolator for isolate the interrupted busbars from each other
- ⑬ DIN Rail for cover for using on the busbar cover
- ⑭ Adapter for 32A, 63A and 100A single or Combination bottom or top feed

### Technical data EN 60439

	Socket base ZLS806/808	Incoming terminal block ZLS224/225	Incoming terminal component ZLS250-255	Adapter 32A	Adapter 63A	Adapter 100A	Outer terminal ZLS812, 815	Outer terminal ZLS813, 816
Rated voltage $U_n$ :	max. 400/690V~							
Rated current $I_n$ :	-	Main terminal 160A Auxiliary terminal 40A	200A	32A	63A	100A	32A	100A
Space required (Modules) per element:	6 (108 mm) 8 (144 mm)	4 (72 mm)	2 (36 mm)	1 (18 mm)	1 (18 mm)	4 (72 mm)	0,5 (9 mm)	1 (18 mm)
Cable cross section:	-	Cable 50 mm <sup>2</sup> (2x25 mm <sup>2</sup> ) Main terminal Strand 10 mm <sup>2</sup> Auxiliary terminal	1 x 95 mm <sup>2</sup>	-	-	-	10 mm <sup>2</sup>	16-50 mm <sup>2</sup>
Type of feeder cable:	-	Cable or strand	Cable or strand	-	-	-	Cable or strand	Cable or strand
Rated insulation voltage $U_i$ :	690V~							
Rated impulse withstand voltage $U_{imp}$ :	8kV							
Rated frequency:	50/60Hz							
Overvoltage category:	III							
Rated short-time withstand current $I_{cw}$ :	10kA/300ms							
Rated conditional short-circuit current ( $I_{cc}$ ):	10kA/50ms for auxiliary circuit 32,5kA/400V AC							
Rated peak withstand current $I_{pk}$ :	17kA							
Rated fused short-circuit current $I_{cf}$ :	50kA							
Rated peak withstand current $I_{df peak}$ :	105kA							
Back up: Circuit breaker Sace:	Tmax 250A							
Resistance, reactance and impedance values ( $I_n > 100A$ ):	$R_{20}$ : 0,58m $\Omega$ $R_1$ : 0,71m $\Omega$ $X_1$ : 0,15m $\Omega$ $Z_1$ : 0,98m $\Omega$							
Degree of protection:	IP 2x (to be realized by installer)							
Ambient temperature:	max. 55°C							
Plastics:	Halogen- and cadmium free							

Approbation/Standards:



EN60439-1, IEC 60439-1  
EN60439-2, IEC 60439-2



### Technical data US

Rated voltage:	690V AC
Rated current (end feed):	100A
Rated current (center feed):	150A
Short circuit rating:	50kA with fuse 150A ggl/Gg
<b>Incoming terminal block, standard:</b>	
Maximum rated voltage:	600V AC
Maximum rated current:	150A
Main terminal:	10 AWG to 1/0 AWG
<b>Incoming terminal element:</b>	
Maximum rated voltage:	600V AC
Maximum rated current:	150A
Main terminal:	8 AWG to 3/0 AWG
<b>Adapter 30A:</b>	
Rated voltage:	600V AC
Rated current:	30A
Short circuit rating:	50kA with fuse 150A ggl/Gg
<b>Adapter 60A:</b>	
Rated voltage:	600V AC
Rated current:	60A
Short circuit rating:	50kA with fuse 150A ggl/Gg

# Unifix L

## Main characteristics

### Busbars

The busbars consist of a support, containing a system of conductors with 100A capacity (central power supply) and 25 kA short-circuit current (conditioned). They are available in the two-pole and four-pole version, and in 12, 18, 24 or 36 module widths, and can be installed in switchboards with 400, 600 and 800mm widths (except 18 modules) respectively. Fixing is carried out by dove-tailing on the rear of the DIN rail (GD4002 - GD6002 and GD8002), and installation is in two modules with H=200mm.

Thanks to the structure of the busbar system, it is possible to hook the special supports AD1009 onto the rear for 60x80mm maximum dimension duct.

### Power supply module with cable

The 63A power supply module, in the two-pole and four-pole versions, is coupled directly into the busbar conductors. It has overall dimensions equivalent to two base modules (17.5mm) and allows the busbars to be supplied directly when the main row circuit-breaker is not provided.

The four-pole version, with 16mm<sup>2</sup> section, is divided into the following cable lengths: 250mm (ED3090); 400mm (ED3405); 800mm (ED3413); 1500mm (ED3439).

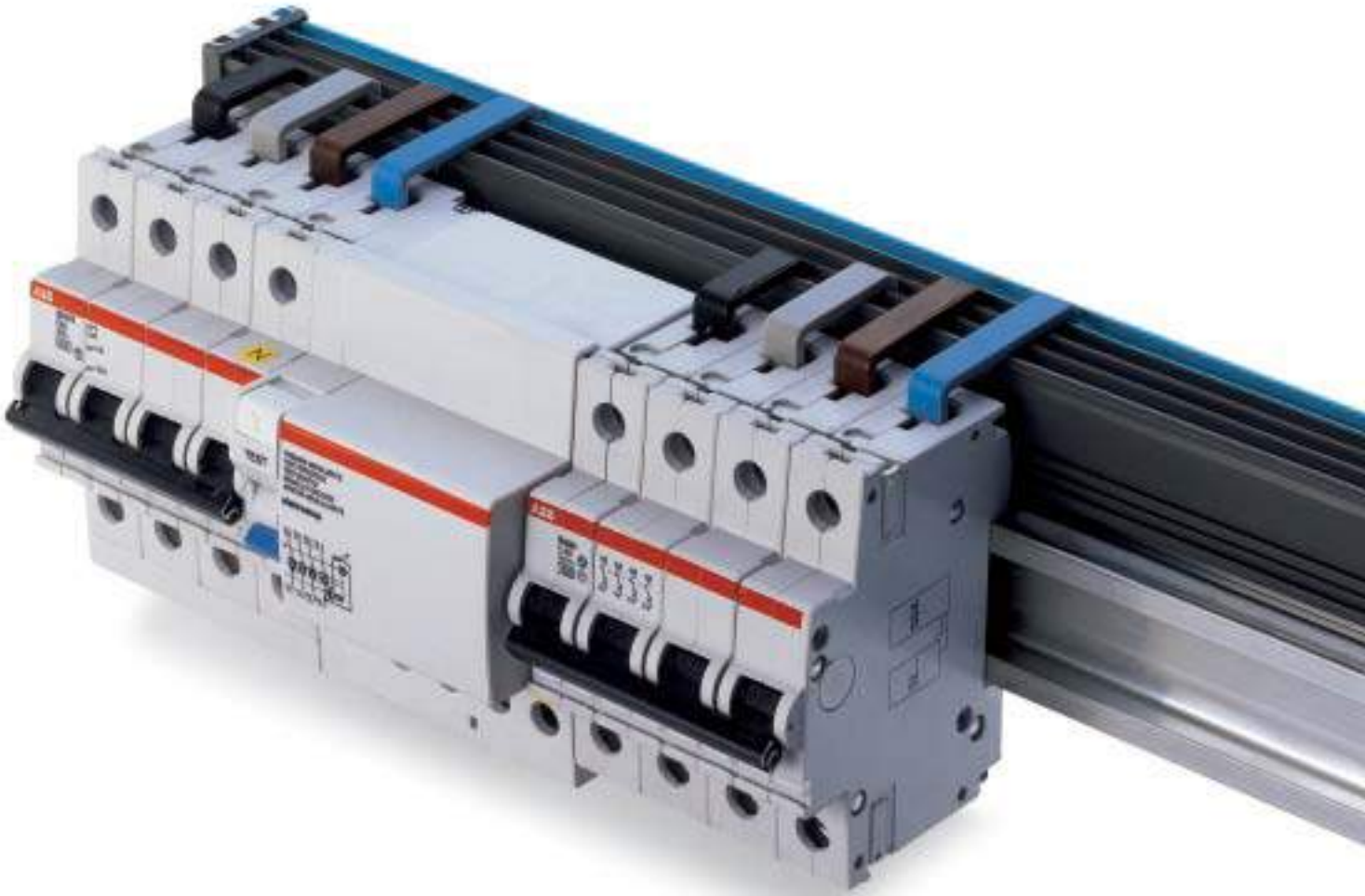

Raceway supports may be fastened onto the back of the bars.



The series L may be installed in cabinets using special brackets that simply fasten onto the switchboard frame.



Unlike traditional racks, the variable pitch makes it possible to use equipment of different polarities together.

# Unifix L

## Main characteristics

### Power supply module without cable

The single-pole 100A power supply module in the L1, L2, L3, N versions (ED3101-ED3102-ED3103-ED3104) is coupled directly into the busbar conductors.

It has overall dimensions equivalent to one base module (17.5mm) and allows the busbars to be supplied directly when the main row circuit-breaker is not provided.

It is fitted with a terminal which allows connection of a conductor with 35mm<sup>2</sup> section.

### Power supply terminals

The single-pole 100A (ED3100) power supply terminal is connected directly to the front terminals of any ABB SACE modular circuit-breaker, allowing supply of the busbars through the main row circuit-breaker. It is fitted with a terminal which allows connection of a conductor with 35mm<sup>2</sup> section.

The single-pole 63A (ED3140) power supply terminal has the same characteristics as the previous one and is fitted with a terminal which allows connection of a conductor with 25mm<sup>2</sup> section.

### Connections for apparatus

The connections consist of small insulated copper busbars, cut and bent to size. They allow power supply between each terminal of the Pro M System modular apparatus and the busbar system. The connections are provided according to the polarity of the

apparatus to be cabled (connectors for L1, L2, L3, N and in the version dedicated to 1P + N apparatus in a DIN module are available). The supports with cable for auxiliary apparatus supply are also available, and these allow cabling of this apparatus placed side by side in the same row as the modular circuit-breakers.

### Technical characteristics

Rated service voltage (Ue)	415V AC	
Rated insulation voltage (Ui)	500V AC	
Rated impulse withstand voltage (Uimp)	6kV	
Rated frequency	50/60Hz	
Rated current (I <sub>n</sub> )	central power supply	100A
	lateral power supply	80A
Maximum installable circuit-breaker size	100A	
Conditioned short-circuit current (I <sub>cc</sub> )		
With circuit-breaker	System pro - M	up to 25kA
Dissipated power	The dissipated power is negligible (less than 3%) with regard to the power dissipated by the circuit-breakers	
Degree of protection IP20	yes	
Characteristics of the insulating material	Self-extinguishing thermoplastic V1 (UL94)	
Characteristics of the conductor material	Copper (Electrolytic copper?)	

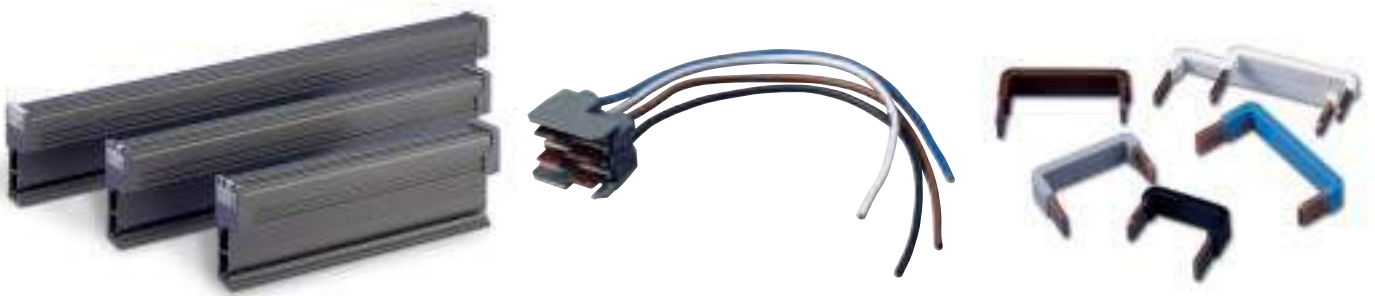



# Unifix L

## System components

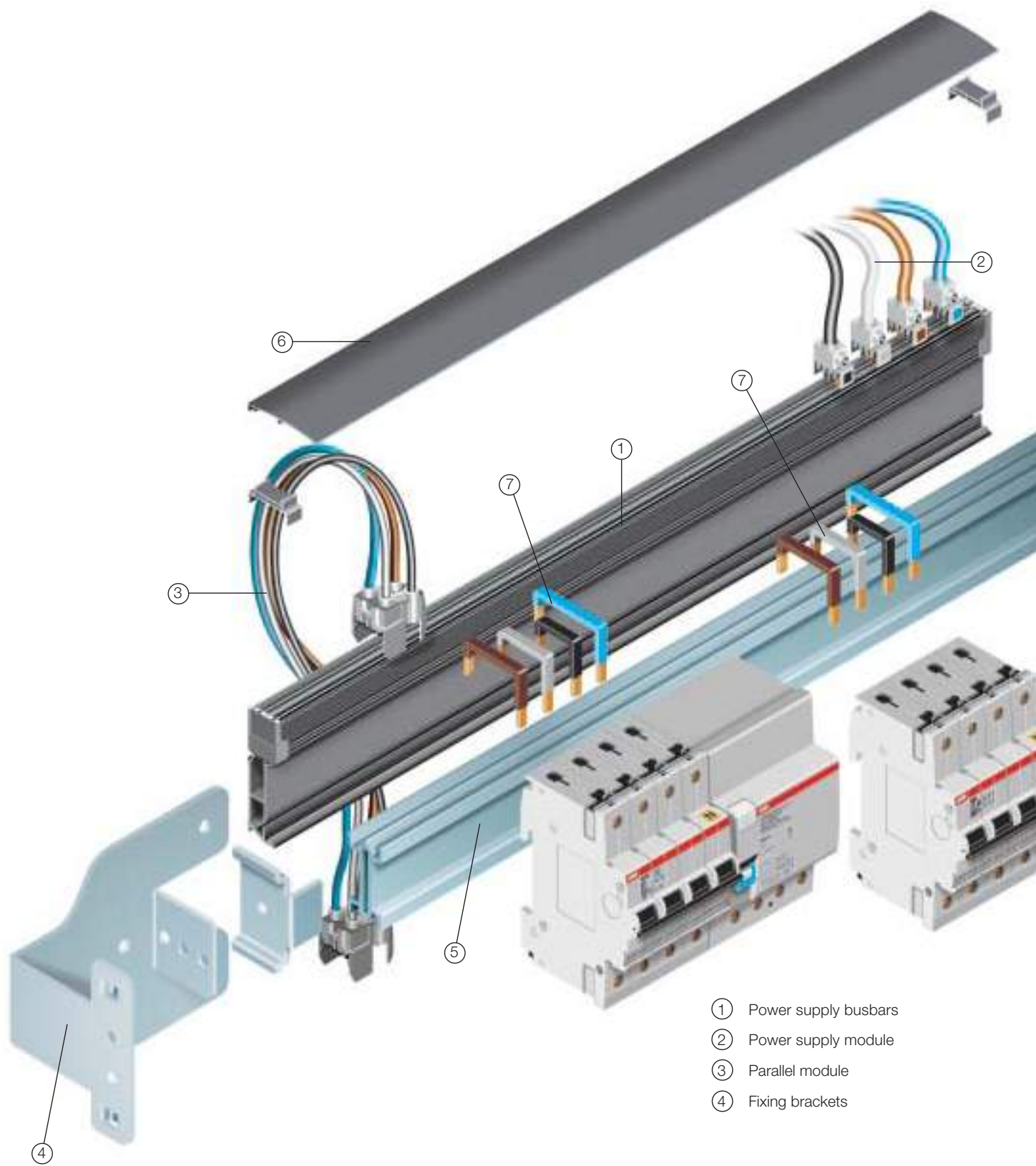

- ① Power supply busbars
- ② Power supply module
- ③ Parallel module
- ④ Fixing brackets

# Unifix L

## System components

### Unifix L

#### Power supply busbars

These have a rated current of 100A with central power supply and 80A with lateral power supply. There are two basic configurations, two-pole and four-pole, in the different lengths from 12 to 36 DIN modules DIN. They are inserted in a plastic section which guarantees IP20 degree of protection. Fixing is snap-on onto the rear of the DIN rail, without the need for any accessories.

#### Power supply module

There are two different types of power supply modules: the first consists of single-pole terminals with the dimensions of one module (L1-L2-L3-N) to which flexible conductors can be connected, with a cross-section up to 35mm<sup>2</sup> and any desired length. The second consists of four-pole modules (2 DIN modules in width), with conductors already connected, with an pre-established cross-section and length (350, 1500, 2500mm).

#### Parallel module

This allows two busbar systems to be placed in parallel. It consists of two lengths of cable of pre-established cross-section and length (400, 600, 800, 1500mm) headed on both side with four-pole modules (2 modules in width).

#### Fixing brackets

These allow a single DIN rail to be fixed with Unifix L in the correct position inside the switchboard, without any type of mechanical working. The special shape of this support allows the cable duct to be fixed.

#### DIN rail with double section

The DIN rail consists of an extremely rigid aluminium section, with a double hooking system: a front one dedicated to the apparatus and a rear one dedicated to Unifix.

#### Cover section

This prevents any cable cut-offs falling into the busbar system, thereby increasing user safety.

#### Connections for modular circuit-breakers

These connect circuit-breaker and busbars, and consist of small rigid insulated copper "bridges", of different colours and lengths according to the reference phase. On one side they are screwed to the inside of the terminal, on the other they are inserted into the busbar system.

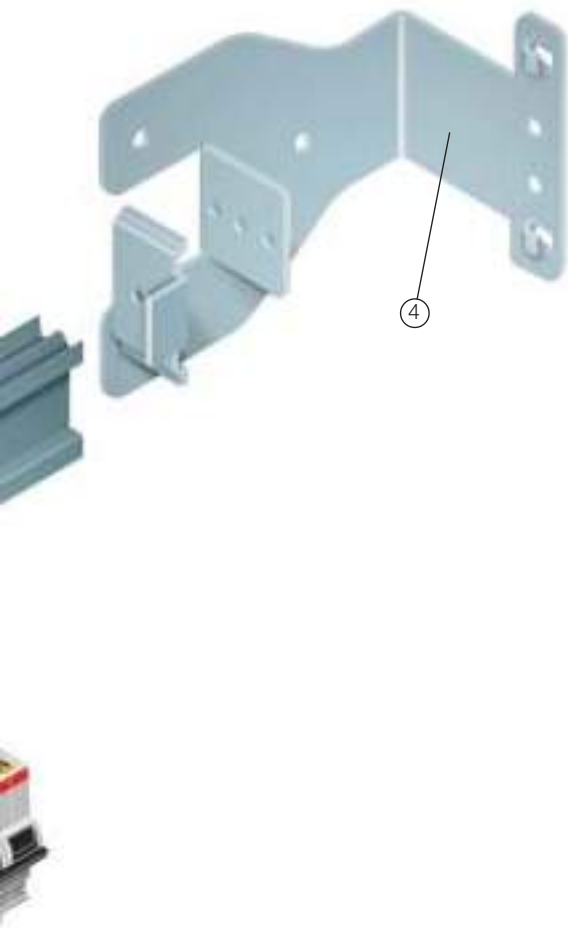

- ⑤ DIN rail with double section
- ⑥ Cover section
- ⑦ Connections for modular circuit-breakers

# Unifix L

## System applications

The use of the Unifix L system is highly recommended for constructing terminal distribution switchboards, for the service sector, where there are a high number of circuits and therefore of circuit-breakers.

This highly flexible system can satisfy requirements linked to these types of application which, being subject to numerous circuit modifications, require simple and "clean" cabling.

This cabling system has been tested and certified by ABB in relation

to the Standards in force, providing a further guarantee for the user.

There are many circuit possibilities offered by Unifix L; by means of the power supply module for busbars (power supply: busbars-apparatus), or directly by means of conductors fitted with a cable terminal (power supply: terminals of the circuit-breakers). In this case, the circuit situation of a main row circuit-breaker and branched circuit-breakers is obtained.



**Due different single-phase circuits on a single 24 module DIN rail**

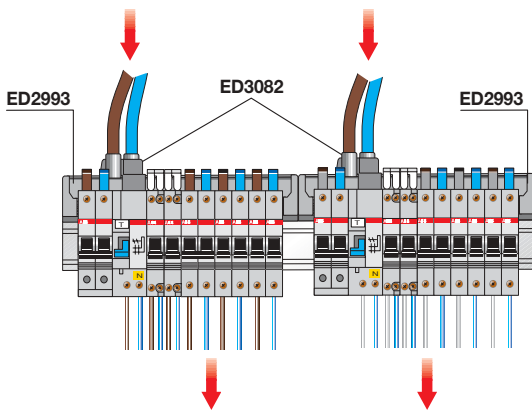

**Busbar power supply by means of circuit-breaker fed from the top placed centrally**

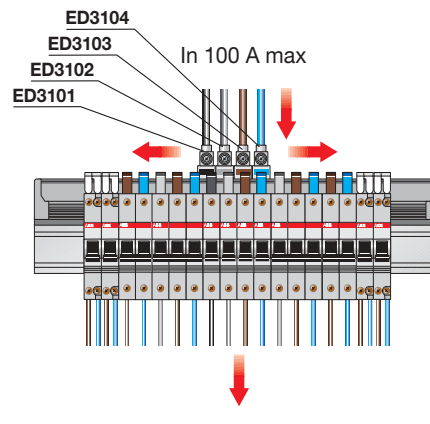

**Example of main and shunted power supply**

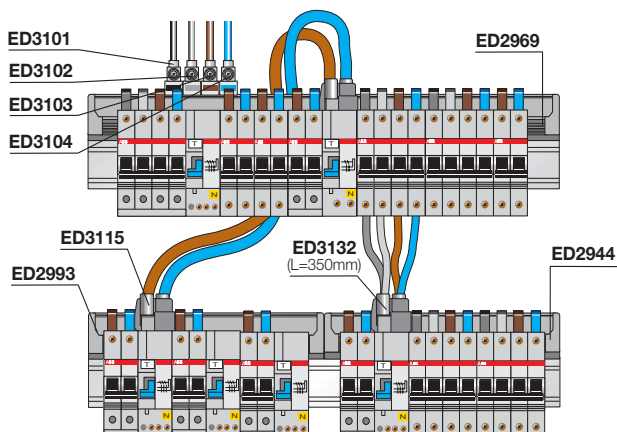

**Busbar power supply by means of main row circuit-breaker fed from the top, placed laterally**

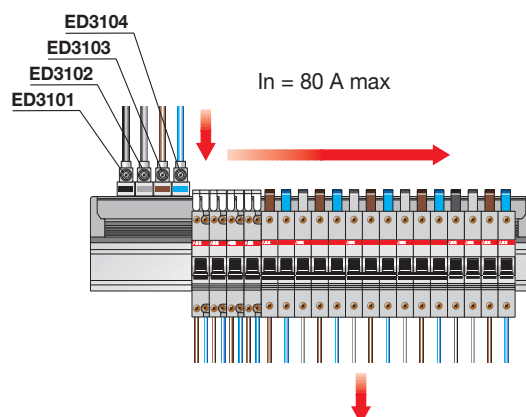

# Unifix L

## System applications

Busbar power supply by means cable terminal placed under the head of the circuit-breaker terminal and branch with parallel module

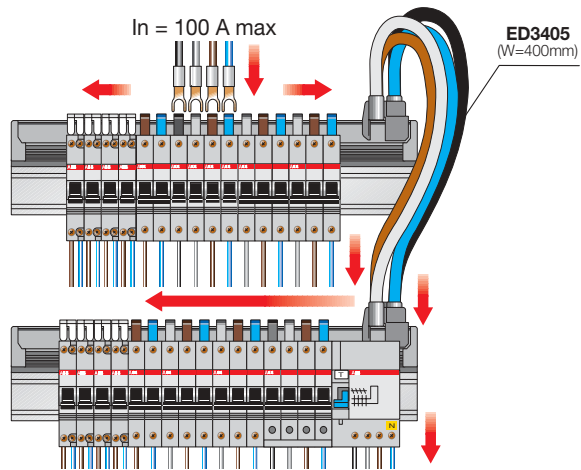

Direct busbar power supply by means of power supply module (supplied without cables) and branch by means of power supply module.

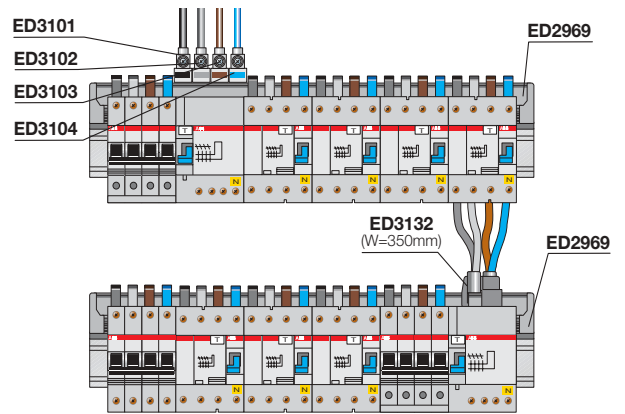







**ABB SACE S.p.A.**

*Automation and Distribution Boards Division*  
23846 Garbagnate Monastero (LC) - Italy  
Via Italia, 58  
Tel.: +39 031.3570.111  
Telefax: +39 031 3570.228

**<http://bol.it.abb.com>**



**ABB Switzerland Ltd**

*CMC Low Voltage Products*  
Fulachstrasse 150, P.O. Box  
CH-8201 Schaffhausen  
Phone +41 58/586 41 11  
Telefax +41 58/586 42 22  
E-Mail [cmc@ch.abb.com](mailto:cmc@ch.abb.com)

**[www.abb.com](http://www.abb.com)**